

Please go to [www.quoizel.com](http://www.quoizel.com) for product cleaning tips. Go to the **Care + Maintenance** selection.

**Tools Required:** Flathead screwdriver, Phillips screwdriver, pliers, wire cutters, wire strippers, electrical tape, safety glasses.

**Light Source:** LED 22W

**Estimated Assembly Time:** 20-30 minutes

**Preparation:** Identify and inspect all parts before beginning installation. Check package content list and diagrams below to ensure all parts are present. If any parts are missing or damaged, do not attempt to assemble, install, or operate the fixture. Contact your original place of purchase.

### ⚠ Warnings and Cautions

Turn off electricity at circuit breaker or main fuse box before installation. Consult a licensed electrician if in doubt.

These instructions are provided for your safety. It is very important you read them completely before installing the fixture. We strongly recommend that a licensed, professional electrician perform the installation.

### Package Contents

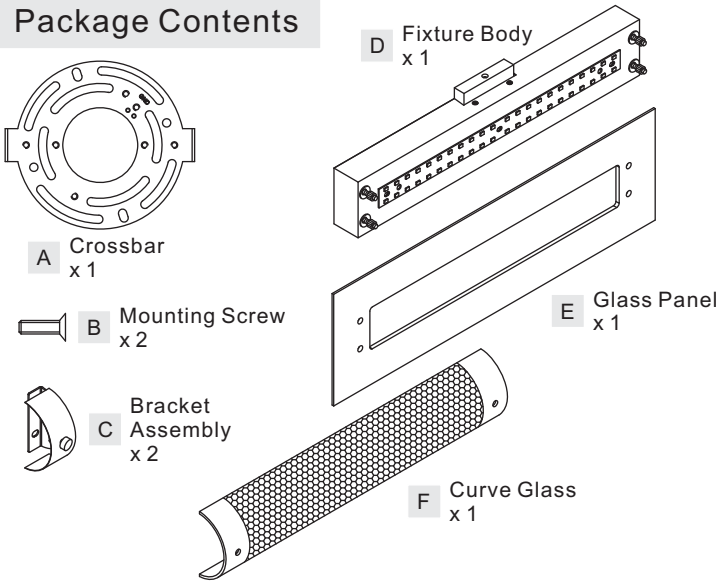

### STEP 1 - Install Glasses

- Remove thumb nuts from bolts on the Fixture Body (D).
- Remove lock screw to separate curve metal from bracket.
- Place washer, Glass Panel (E) and bracket onto bolts on the Fixture Body (D). Secure by threading thumb nuts onto bolts. Hand tighten until snug.
- Place the Curve Glass (F) and curve metals onto brackets and secure with previously removed lock screws. Hand tighten until snug.

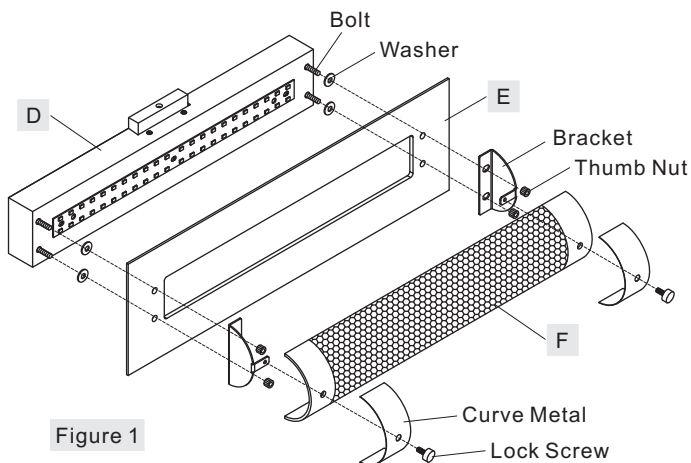

Figure 1

### STEP 2 - Install the Crossbar to the junction box

- Attach the Crossbar (A) to the Outlet Box with the head of the Green Ground Screw facing you. Secure it with Outlet Box Screws (not included), tighten until snug.

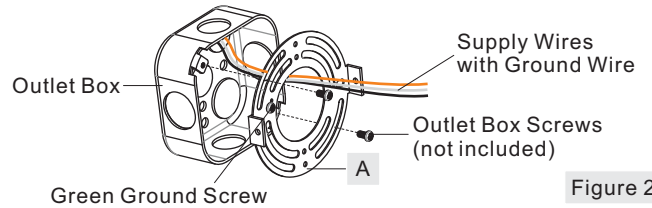

Figure 2

### STEP 3 - Wire Connections

- Wrap bare or green ground wire around green ground screw on the crossbar, no less than 2 inches from the end of the wire. Tighten the green ground screw.
- Use standard wire connectors (not included) to make all wire connections. Twist connectors until wires are tightly joined together. Wrap each connection with approved electrical tape and carefully stuff all the connected wires into the Outlet Box.

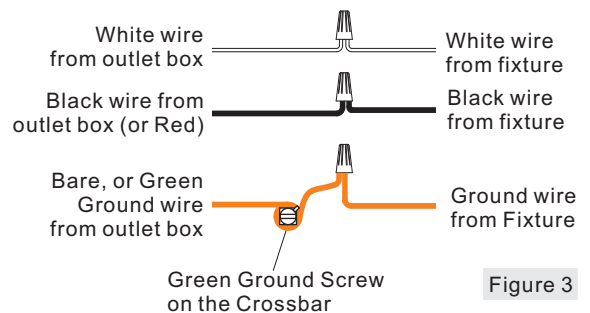

Figure 3

### STEP 4 - Install the Fixture Body

- Place the backplate of the Fixture Body (D) onto the Crossbar (A) and secure with Mounting Screws (B). Tighten until snug with screwdrivers.

Your fixture is now assembled and ready to use. Enjoy!

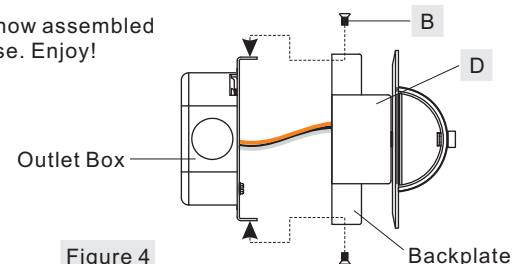

Figure 4

PCGZ8522C

FINISH: POLISHED CHROME

NOTE: ALL DIMENSIONS ARE ROUNDED UP TO THE NEAREST 1/4"

